



EMME ANTINCENDIO S.r.l.

www.emme-italia.com

23052-7

5Kg Co2 FIRE EXTINGUISHER



OPTIONAL



- CYLINDER  
Alloy steel, epoxy polyester powder painting, Red Ral 3000.
- EXTINGUISHING AGENT  
Carbon Dioxide 99,99%
- VALVE  
CPF brass M 25X2, levers with red painting RAL3000.
- USE  
B fire rating (flammable liquids)
- BRACKET  
Wall-mounted in standard equipment.

5Kg Co2 fire extinguisher, temperature range from -30°C to +60°C, manufactured in accordance to **EN 3-7**, approved to European Marine Directive **MED 2014/90/EU, S.O.L.A.S.** (Safety of life at sea) '74 (2000), certified according to the directive for pressure equipment PED 2014/68/EU.

Quality Product certification guaranteed by Bureau Veritas Italia.

Suitable for use on fire involving voltages of up to 1000 volts.

AVAILABLE VERSIONS



N.	CODE	DESCRIPTION
1	28052-7	5kg Co2 fire extinguisher, complies <b>MED 2014/90/EU</b>

APPROVED/CERTIFIED FIRE EXTINGUISHER:



**FIRE RATING :**



113

## 5Kg Co2 FIRE EXTINGUISHER

### TECHNICAL SPECIFICATIONS

FIRE RATING	113 B
EXTINGUISHING AGENT	Co2 99,99%
TEMPERATURE RANGE	-30°C +60°C
NOMINAL CHARGE	5 Kg
FULL WEIGHT	~ 13,8 Kg
DIMENSIONS	Height 750 mm Diameter 136 mm
DISCHARGE TIME	15 sec.
MAX VALVE TIGHTENING	128 Nm
CYLINDER PRESSURE TEST	PT 250 bar
CYLINDER VOLUME	7,5 L.
SAFETY VALVE	Set 195 + 15/- 23 bar
CYLINDER MATERIAL	Alloy steel
EXTERNAL/INTERNAL TREATMENT	Sandblast and epoxy polyester powder painting, Red Ral 3000 colour

### PACKAGING

STANDARD :  
nr. 65 pieces for box + 15 in single packaging on pallet 100x120

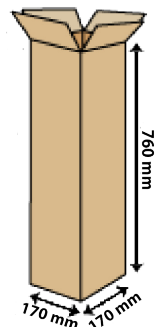
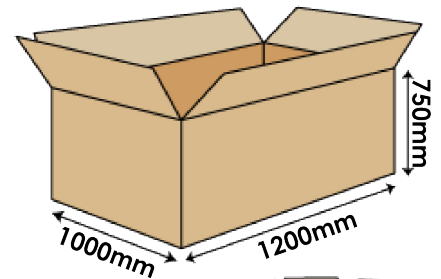

Single packaging on request

### MAINTENANCE AND INSTALLATION

For outdoor or marine installation is recommended to protect the fire extinguisher with cover or box. Maintenance according to the norm in use in utilization country.

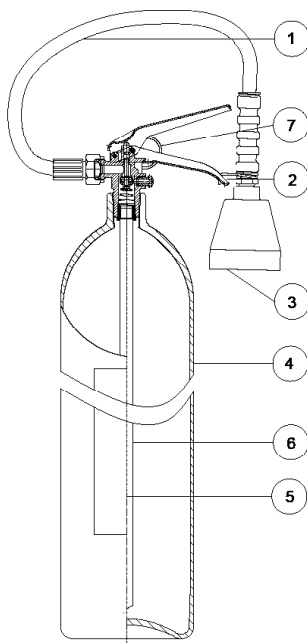

### SPARE PARTS

NUMBER	DESCRIPTION	CODE
1	Hose SAE 100 R1 T 1/2"	0294
2	Valve M 25 X 2	0213C-1
3	Horn	0332
4	Cylinder	0110-1
5	Label	0064-7
6	Aluminum dip tube	0160-1
7	Safety pin	0284
	Safety pin seal	0285
	Safety valve	0262C
OPTIONAL	Iron marine bracket red painting	0319
OPTIONAL	Stainless steel marine bracket	1465
OPTIONAL	Iron ring wall-mounted, red painting, Europe model	1907-2

### EMME ANTINCENDIO S.r.l

Factory: Via del Molino, 40 – 52010 Corsalone (AR) – Italy – Tel. +39.0575.511320  
Warehouse: Via G. Di Vittorio, 11 – 20017 Mazzo di Rho (MI) – Italy – Tel. +39.0293900399  
E-mail: [info@emme-italia.com](mailto:info@emme-italia.com) – web site: [www.emme-italia.com](http://www.emme-italia.com)  
P.IVA/ C.F. 11208251006 – R.E.A. FI-632545

File name	Code	Date	Rele.	Check	Rev.	Pag.
ds_23052-7	23052-7	12/10/17	M.R	AA	1	2