

# Technical Manual



SAFETY  
FOR  
FUTURE



www.emme-italia.com

Via del Molino, 40 - 52010 Corsalone (AR) - Italy - info@emme-italia.com - Tel. +39.0575.511320  
P.IVA/ C.F. 11208251006 - R.E.A. AR-159122

## GW2P 22020-700L : Portable Fire Extinguisher, 2 L Foam

EXTINGUISHING AGENT SUITABLE FOR LITHIUM BATTERIES



FLUORINE FREE



- **CYLINDER**  
In high-strength alloy steel, deep drawing, external powder painting Red Ral 3000.
- **EXTINGUISHING AGENT**  
Fluorine free foam, water based.
- **PROPELLANT**  
Nitrogen (N<sub>2</sub>).
- **VALVE**  
M. 30x1.5, brass body, levers with green painting Ral 6018.
- **USE**  
A B F fire rating (solid materials, flammable liquids, cooking oils).

REPRODUCTION IS PROHIBITED

Note: image is for illustrative purpose only, the product purchased can has some difference

2 L foam fire extinguisher, temperature range from +5°C to +60°C, manufactured in accordance to **UNI EN 3-7**, approved Marine Equipment Directive **MED 2014/90/EU**, certified according to the directive for pressure equipment **PED 2014/68/EU**. Manufactured according to productions checks as agreed with **EN 3-10**. Quality Product certification guaranteed by Bureau Veritas Italia. Suitable for use on fire involving electrical voltages up to 1'000 V, at a minimum distance of 1 meter.

APPROVED/CERTIFIED FIRE EXTINGUISHER:



FIRE RATING :



File name	Type of document	Fire Extinguisher Model	Date	Rele.	Check	Rev.	Pag.
22020-700L_GW2P_Technical manual	Technical manual	GW2P_22020-700L	26/01/26	S.R.		0	1/4

# GW2P 22020-700L : Portable Fire Extinguisher, 2 L Foam

- **INSTALLATION** The installation must be carried out in accordance with the provisions in force in the country where the device is used. The commissioning and maintenance activities for maintaining efficiency must be carried out in accordance with the document **PSP\_1-B\_ENG** by qualified
- **USE** technical personnel and in compliance with the regulations in force in the country of use.
- **MAINTENANCE** Any tampering or intervention carried out by unqualified personnel will void the product warranty.  
It is recommended to place the device in a dry place protected from atmospheric agents.

## TECHNICAL SPECIFICATIONS

FIRE RATING	8 A 34 B 25 F
EXTINGUISHING AGENT	100% Green Wave Premix Lith-M
PROPELLANT	Nitrogen (N <sub>2</sub> ), 15 Bar at 20°C
TEMPERATURE RANGE	+5°C / +60°C
NOMINAL CHARGE	2 Liters
FULL WEIGHT	~ 3,90 Kg (with bracket)
DIMENSIONS	Height 385 (base - valve) +/- 5 mm Diameter (cylinder) 110 +/- 2 mm
DISCHARGE TIME	~ 9,5 seconds
CYLINDER PRESSURE TEST	PT 27 bar
CYLINDER VOLUME	2,45 L
SAFETY DEVICE	Set between 20 and 26 bar
CYLINDER MATERIAL	Alloy steel
TREATMENT	Outside: Sandblast and powder painting, Ral 3000 Inside: Plastic coating

## PACKAGING

(Note: quantities and measurements are indicative and can be subject at changes)

### STANDARD

Note: minimum 8 pieces  
Maximum nr. 256 pieces for pallet  
(32 boxes with 8 pieces for each one)  
Pallet dimensions 100x120 cm

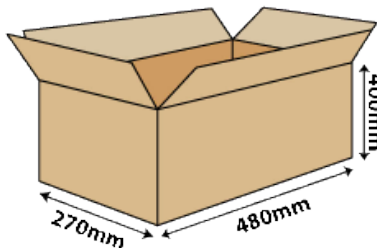

### ON REQUEST: SINGLE PACKAGING

- maximum 216 pieces on pallet 120x80x175H

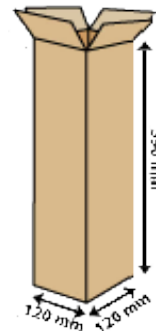

## TRANSPORT DISPOSAL

Land transport : Exemption for the purposes of ADR disposal 594  
Ship Transport : IMDG Code - UN 1044 class 2.2 Fire Extinguishers

File name	Type of document	Fire Extinguisher Model	Date	Rele.	Check	Rev.	Pag.
22020-700L_GW2P_Technical manual	Technical manual	GW2P_22020-700L	26/01/26	S.R.		0	2/4

# GW2P 22020-700L : Portable Fire Extinguisher, 2 L Foam

## COMPONENTS AND SPARE PARTS LIST

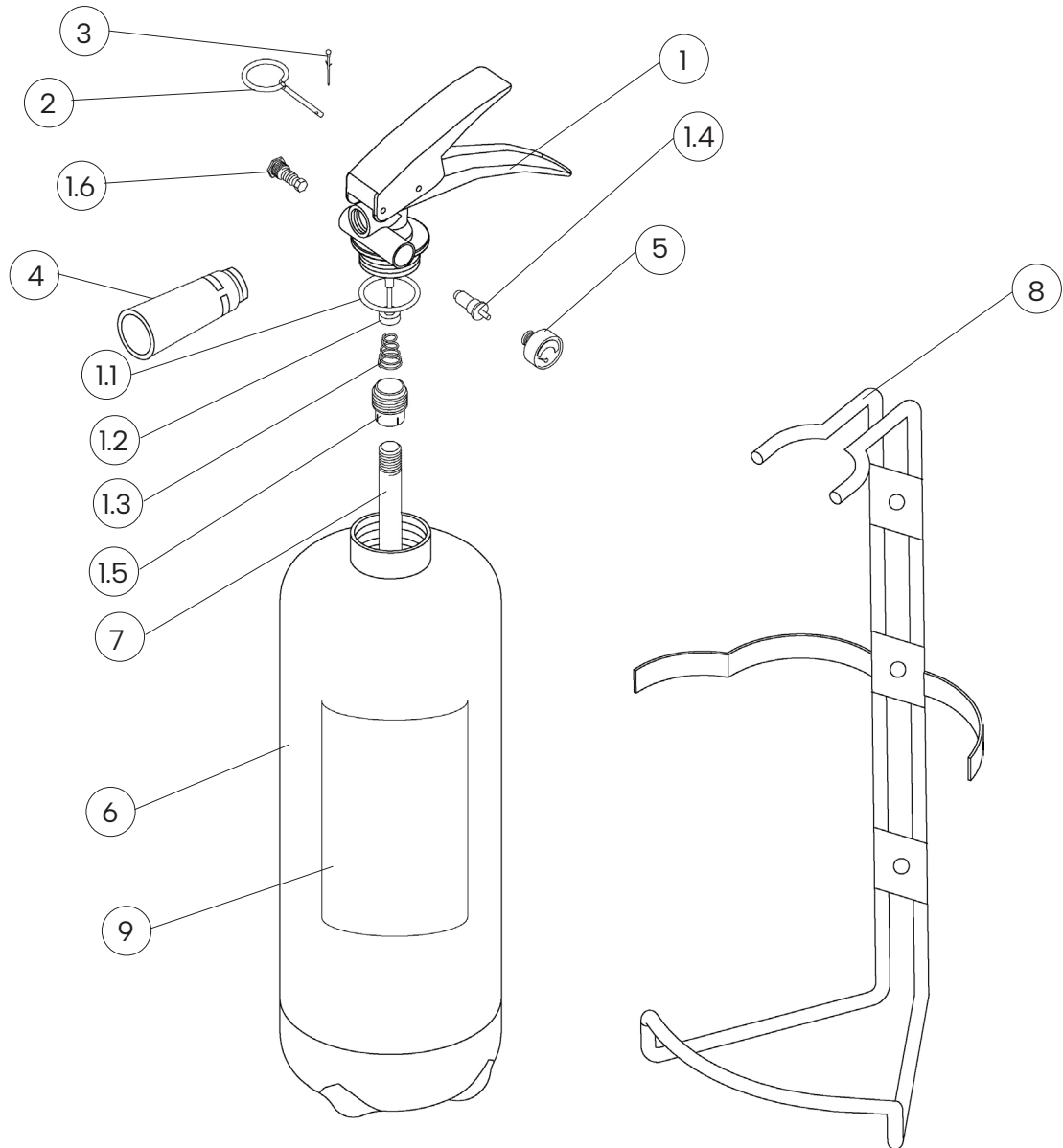

NUM.	DESCRIPTION	CODE
1	Valve M. 30x1.5	SL0211-3V
1.1	O-ring valve	n.a.
1.2	Valve stem	n.a.
1.3	Internal spring of the valve	n.a.
1.4	Test valve for pressure gauge	1163
1.5	Dip tube holder	n.a.
1.6	Safety device	0261R
2	Safety pin	0282-1
3	Safety pin seal	0285

NUM.	DESCRIPTION	CODE
4	Dispensing nozzle	1645-5
5	Pressure gauge	1576
6	Cylinder	1579-5
7	PVC dip tube with filter	0152F
8	Bracket	0327
9	Label	1581-700L

The spare part at number 1 includes already all others components indicated from 1.1 to 1.6  
 "n.a." mean that the component is not available as single spare part

File name	Type of document	Fire Extinguisher Model	Date	Rele.	Check	Rev.	Pag.
22020-700L_GW2P_Technical manual	Technical manual	GW2P_22020-700L	26/01/26	S.R.		0	3/4

## Prerequisite when using the fire extinguisher on lithium batteries

According to tests executed with this fire extinguisher, it's possible to stop the combustion of a lithium-ion battery with a water based fire extinguisher with foam additives. It has been verified that the use of the fire extinguisher allows to lower the temperature and control any re-ignitions of the cells present inside the battery (generated by the chain reaction of the same and due to their shape inside the battery pack).

The fire extinguisher tested is therefore effective in containing the flames emanated from a battery with same or inferior characteristics compared to the one tested.

*\*NOTE: the test was executed on a new battery and so at full efficiency.*

### SAFETY WARNING



*The combustion of lithium-ion batteries releases very harmful gases and fumes. Direct exposure to high concentrations of gases emanating from the combustion of lithium-ion batteries can cause serious damage to health. Lithium-ion batteries can have unpredictable phenomena during fire, such as explosive reactions caused by the pressure of the cells inside the battery pack. It's advisable to use appropriate safety devices. The use of fire extinguisher is recommended for professional and expert staff. The use of fire extinguisher by uninformed people can lead to lower results and cause damage to involved people.*

### DISCLAIMER

The result of the tests performed refers exclusively to the fire extinguisher model used during the tests themselves. The fast development of lithium-ion batteries and portable fire extinguishers means that the performance achieved during the test phase is not guaranteed when using lithium-ion batteries or shutdown techniques other than those tested. It is not possible to understand where and to what extent these fire extinguishers can be installed due to the outer casing of the lithium-ion battery pack.

The fire extinguishers tested are intended to help contain the principle of fire resulting from the triggering of a lithium-ion battery.

File name	Type of document	Fire Extinguisher Model	Date	Rele.	Check	Rev.	Pag.
22020-700L_GW2P_Technical manual	Technical manual	GW2P_22020-700L	26/01/26	S.R.		0	4/4