



EMME ANTINCENDIO S.r.l.

www.emme-italia.com

25094-1

9 Kg Potassium Sulphate Powder FIRE EXTINGUISHER



- **CYLINDER**
Alloy steel, 3 pieces drawing, with clip, epoxy polyester powder painting, Red Ral 3000.
- **EXTINGUISHING AGENT**
BC Powder - Potassium Sulphate.
- **PROPELLANT**
Fire extinguisher pressurized at moment of use with gr. 200 CO₂ cartridge.
- **VALVE**
M. 74x2, lightweight aluminum alloy, activation with percussion method.
- **USE**
B C fire rating (flammable liquids, flammable gas).
- **BRACKET**
Wall-mounted bracket for fire extinguisher with clip, red painting, in standard equipment.

Note: image is for illustrative purpose only, the product purchased can has some differences

9 Kg potassium sulphate powder fire extinguisher, pressurized at moment of use, temperature range from -30°C to +60°C, manufactured in accordance to EN 3-7, certified according to the directive for pressure equipment PED 2014/68/EU.

Quality Product certification guaranteed by Bureau Veritas Italia.

Suitable for use on fire involving electrical voltages up to 1'000 V, at a distance of 1 mt.

APPROVED/CERTIFIED FIRE EXTINGUISHER:



FIRE RATING :



233



© REPRODUCTION IS PROHIBITED

9 Kg Potassium Sulphate Powder FIRE EXTINGUISHER

TECHNICAL SPECIFICATIONS

| | |
|-----------------------------|--|
| FIRE RATING | 233 B C |
| EXTINGUISHING AGENT | EPBC 2051 BC powder - Potassium Sulphate |
| PROPELLANT | Internal cartridge with gr. 200 CO ₂ |
| TEMPERATURE RANGE | -30°C / +60°C |
| NOMINAL CHARGE | 9 Kg |
| FULL WEIGHT | ~ 15 Kg |
| DIMENSIONS | Height 530-545 mm Diameter 182 mm |
| DISCHARGE TIME | 24,5 sec. |
| VALVE TIGHTENING TORQUE | Minimum 40 Nm, Maximum 60 Nm |
| CYLINDER PRESSURE TEST | PT 30 bar |
| CYLINDER VOLUME | 10,3 L. |
| SAFETY VALVE | Set 24 +/- 2 bar |
| CYLINDER MATERIAL | Alloy steel |
| EXTERNAL/INTERNAL TREATMENT | Sandblast and epoxypolyestere powder painting, Red Ral 3000 colour |

PACKAGING

STANDARD : maximum 30 pieces on pallet 100x120x70(h) cm in single packaging

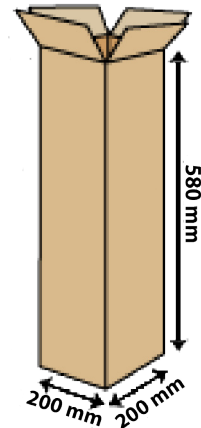

Note: the packaging quantities and measurements are indicative and can be subject at changes

MAINTENANCE AND INSTALLATION

For outdoor or marine installation is recommended to protect the fire extinguisher with cover or box. Maintenance according to the rules in use in utilization country.

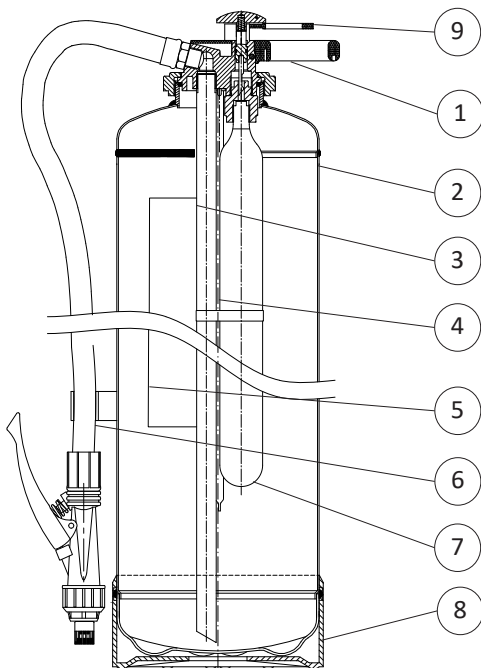

SPARE PARTS

| NUMBER | DESCRIPTION | CODE |
|--------|---|--------|
| 1 | Valve M. 74x2 | 3008-1 |
| 2 | Cylinder | 3009 |
| 3 | PVC dip tube | 3034 |
| 4 | Pressurization dip tube | 3034-1 |
| 5 | Label | 3016-3 |
| 6 | Hose | 3014-1 |
| 7 | gr. 200 CO ₂ cartridge | 3031 |
| 8 | PELD base | 3028 |
| 9 | Safety pin | 0285-1 |
| | Safety pin seal | 0285 |
| | BC powder - Potassium Sulphate (25 Kg recharge) | 2051 |

| File name | Code | Date | Rele. | Check | Rev. | Pag. |
|------------|---------|----------|-------|-------|------|------|
| ds_25094-1 | 25094-1 | 30/10/17 | M.R | | 1 | 2 |

EMME ANTINCENDIO S.r.l
Via del Molino, 40 - 52010 Corsalone (AR) - Italy
info@emme-italia.com - Tel. +39.0575.511320
Others Emme Antincendio s.r.l. warehouses in Italy : Milano - Padova - Reggio Emilia
PIVA/ C.F. 11208251006 - R.E.A. FI-632545