



EMME ANTINCENDIO S.r.l.

www.emme-italia.com

21063-16

6 Kg Powder FIRE EXTINGUISHER



Note: image is for illustrative purpose only, the product purchased can has some differences

- **CYLINDER**
Alloy steel, deep drawing, epoxy polyestere powder painting, Red Ral 3000.
- **EXTINGUISHING AGENT**
ABC Powder - MAP 20 %.
- **PROPELLANT**
Dehumidified air or N₂.
- **VALVE**
M. 30x1.5, brass body, levers with blue painting.
- **USE**
A B C fire rating (solid materials, flammable liquids, flammable gas).
- **BRACKET**
Wall-mounted for valve, in standard equipment.

© REPRODUCTION IS PROHIBITED

6 Kg powder fire extinguisher, temperature range from -30°C to +60°C, manufactured in accordance to **EN 3-7:2008**, certified according to the directive for pressure equipment PED 2014/68/EU.

Quality Product certification guaranteed by Bureau Veritas Italia.

Suitable for use on fire involving electrical voltages up to 1'000 V, at a distance of 1 mt.

APPROVED/CERTIFIED FIRE EXTINGUISHER:



FIRE RATING :



34



233



✓

6 Kg Powder FIRE EXTINGUISHER

TECHNICAL SPECIFICATIONS

FIRE RATING	34 A 233 B C
EXTINGUISHING AGENT	EPW 18462 (ABC Favorit Tertia) ABC powder - MAP 20 %
PROPELLANT	Dehumidified air or N ₂ , 15 Bar at 20°C
TEMPERATURE RANGE	-30°C / +60°C
NOMINAL CHARGE	6 Kg
FULL WEIGHT	~ 9,4 Kg
DIMENSIONS	Height 540 mm Diameter 160 mm
DISCHARGE TIME	23 sec.
VALVE TIGHTENING TORQUE	Minimum 45 Nm, Maximum 68 Nm
CYLINDER PRESSURE TEST	PT 27 bar
CYLINDER VOLUME	7,8 L.
SAFETY VALVE	Set between 20 and 26 bar
CYLINDER MATERIAL	Alloy steel
EXTERNAL/INTERNAL TREATMENT	Sandblast and epoxypolyestere powder painting, Red Ral 3000 colour

PACKAGING

STANDARD : maximum 100 pieces for pallet
(44 pieces for box, max 2 boxes for pallet)
(12 pieces in single packaging)
Pallet dimensions 100x120x160(h) cm

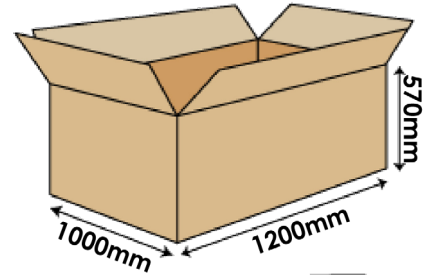

SINGLE PACKAGING

ON REQUEST:

- maximum 64 pieces on pallet 100x120 cm
- maximum 48 pieces on pallet 80x120 cm

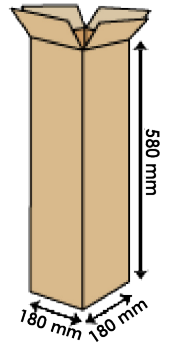

Note: the packaging quantities and measurements are indicative and can be subject at changes

MAINTENANCE AND INSTALLATION

For outdoor or marine installation is recommended to protect the fire extinguisher with cover or box. Maintenance according to the rules in use in utilization country.

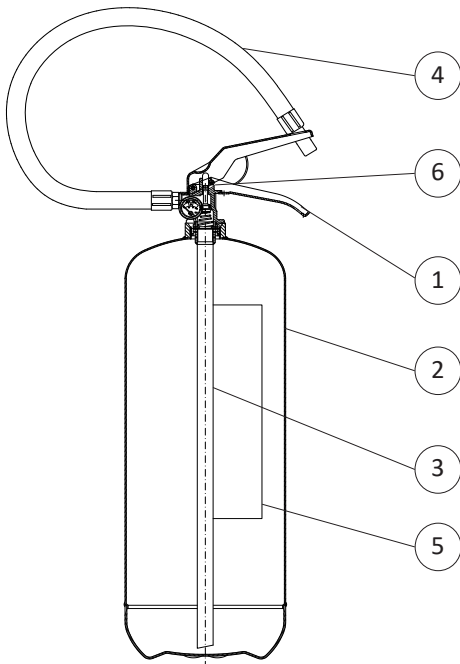

SPARE PARTS

NUMBER	DESCRIPTION	CODE
1	Valve M. 30x1.5	0212KB
2	Cylinder	0104
3	PVC dip tube	0154
4	Hose	0292
5	Label	0054-1
6	Safety pin	0282-1
	Safety valve	0261
	Safety pin seal	0285
	ABC powder - MAP 20 % (6 Kg recharge)	18462-1

File name	Code	Date	Rele.	Check	Rev.	Pag.
ds_21063-16	21063-16	03/01/18	M.R		1	2

EMME ANTINCENDIO S.r.l

Via del Molino, 40 - 52010 Corsalone (AR) - Italy
info@emme-italia.com - Tel. +39.0575.511320

Others Emme Antincendio s.r.l. warehouses in Italy : Milano - Padova - Reggio Emilia
P.IVA/ C.F. 11208251006 - R.E.A. FI-632545