



EMME ANTINCENDIO S.r.l.
www.emme-italia.com

19118-52

100L Water + Additive WHEELED FIRE EXTINGUISHER



Note: image is for illustrative purpose only, the product purchased can has some differences

100 L. water + additive wheeled fire extinguisher, pressurized at moment of use, temperature range from +5°C to +60°C, manufactured in accordance to **UNI EN 1866-1**, approved Marine Equipment Directive **MED 2014/90/EU**, certified according to the directive for pressure equipment **PED 2014/68/EU**.

Quality Product certification guaranteed by Bureau Veritas Italia.

Suitable for use on fire involving electrical voltages up to 1'000 V, at a distance of 1 mt.

- **CYLINDER**
Stainless steel AISI 304, epoxy polyester powder painting, Red Ral 3000.
- **EXTINGUISHING AGENT**
Water + additive .
- **PROPELLANT**
Fire extinguisher pressurized at moment of use with CO₂ external cylinder, complete of protection for valve.
- **CAP**
Brass 2".
- **USE**
A B fire rating
(solid materials, flammable liquids).
- **BRACKET**
Chassis on wheels, welded at the cylinder, red painting RAL3000.

© REPRODUCTION IS PROHIBITED

APPROVED/CERTIFIED FIRE EXTINGUISHER:

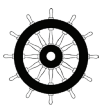

FIRE RATING :



100L Foam WHEELED FIRE EXTINGUISHER

TECHNICAL SPECIFICATIONS

FIRE RATING	A IV B
EXTINGUISHING AGENT	Water + additive (98 % Water + 2 % SC 6)
PROPELLANT	2,5 Kg of CO ₂
TEMPERATURE RANGE	+5°C +60°C
NOMINAL CHARGE	100 L
FULL WEIGHT	~ 165Kg
DIMENSIONS	Height 1350 mm Width 580 mm Depth 560 mm
DISCHARGE TIME	85 sec.
CAP TIGHTENING TORQUE	Minimum 60 Nm, Maximum 70 Nm
CYLINDER PRESSURE TEST	PT 30 bar
CYLINDER VOLUME	134 L.
SAFETY DEVICE	Set between 21 and 26 bar
CYLINDER MATERIAL	Stainless steel AISI 304
EXTERNAL/INTERNAL TREATMENT	Sandblast and epoxy polyestere powder painting, Red Ral 3000 colour

PACKAGING

STANDARD : maximum 2 pieces for pallet
Pallet dimensions 100x120x150(h) cm

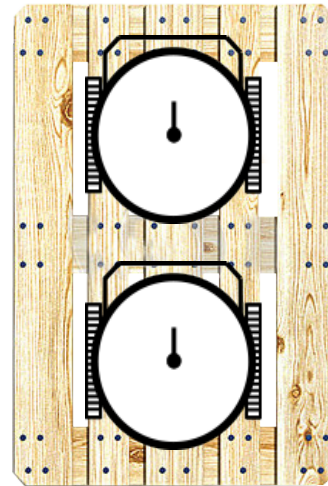

Note: the packaging quantities and measurements are indicative and can be subject at changes

MAINTENANCE AND INSTALLATION

For outdoor or marine installation is recommended to protect the fire extinguisher with cover. Maintenance according to the norm in use in utilization country.

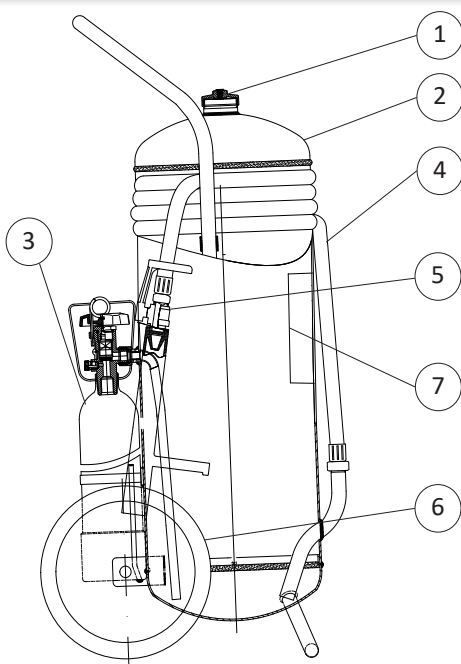

SPARE PARTS

NUMBER	DESCRIPTION	CODE
1	Brass cap, 2"	18463
2	Cylinder	18324
3	External cylinder CO ₂ , complete of protection for valve	n.a.
4	Hose	18422-1
5	Dispensing nozzle (complete of ball valve with control lever)	2181-3
6	Wheel + wheel stop (diam. 400mm)	0125
7	Label	18343
	Additive (1 Lt. concentrate) (To mix with water, suitable for 1 recharge)	1470-1 x 2

File name	Code	Date	Rele.	Check	Rev.	Pag.
ds_19118-52	19118-52	21/05/18	M.R		1	2

EMME ANTINCENDIO S.r.l

Via del Molino, 40 - 52010 Corsalone (AR) - Italy
info@emme-italia.com - Tel. +39.0575.511320

Others Emme Antincendio s.r.l. warehouses in Italy : Milano - Padova - Reggio Emilia
P.IVA/ C.F. 11208251006 - R.E.A. FI-632545