



EMME ANTINCENDIO S.r.l.

www.emme-italia.com

25064-1

6 Kg Potassium Sulphate Powder FIRE EXTINGUISHER



CLIP DETAIL



- **CYLINDER**
Alloy steel, 3 pieces drawing, with clip, epoxy polyester powder painting, Red Ral 3000.
- **EXTINGUISHING AGENT**
BC Powder - Potassium Sulphate.
- **PROPELLANT**
Fire extinguisher pressurized at moment of use with gr. 150 CO₂ cartridge.
- **VALVE**
M. 74x2, lightweight aluminum alloy, activation with percussion method.
- **USE**
B C fire rating (flammable liquids, flammable gas).
- **BRACKET**
Wall-mounted bracket for fire extinguisher with clip, red painting, in standard equipment.

Note: image is for illustrative purpose only, the product purchased can has some differences

6 Kg potassium sulphate powder fire extinguisher, pressurized at moment of use, temperature range from -30°C to +60°C, manufactured in accordance to **EN 3-7**, certified according to the directive for pressure equipment PED 2014/68/EU.

Quality Product certification guaranteed by Bureau Veritas Italia.

Suitable for use on fire involving electrical voltages up to 1'000 V, at a distance of 1 mt.

APPROVED/CERTIFIED FIRE EXTINGUISHER:



FIRE RATING :



233



6 Kg Potassium Sulphate Powder FIRE EXTINGUISHER

TECHNICAL SPECIFICATIONS

FIRE RATING	233 B C
EXTINGUISHING AGENT	EPBC 2051 BC powder - Potassium Sulphate
PROPELLANT	Internal cartridge with gr. 150 CO ₂
TEMPERATURE RANGE	-30°C / +60°C
NOMINAL CHARGE	6 Kg
FULL WEIGHT	~ 10,5 Kg
DIMENSIONS	Height 515-530 mm Diameter 152 mm
DISCHARGE TIME	19 sec.
VALVE TIGHTENING TORQUE	Minimum 40 Nm, Maximum 60 Nm
CYLINDER PRESSURE TEST	PT 30 bar
CYLINDER VOLUME	6,7 L.
SAFETY VALVE	Set 24 +/- 2 bar
CYLINDER MATERIAL	Alloy steel
EXTERNAL/INTERNAL TREATMENT	Sandblast and epoxypolyestere powder painting, Red Ral 3000 colour

PACKAGING

STANDARD : maximum 30 pieces on pallet 100x120x65(h) cm in single packaging

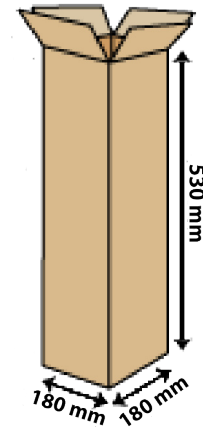

Note: the packaging quantities and measurements are indicative and can be subject at changes

MAINTENANCE AND INSTALLATION

For outdoor or marine installation is recommended to protect the fire extinguisher with cover or box. Maintenance according to the rules in use in utilization country.

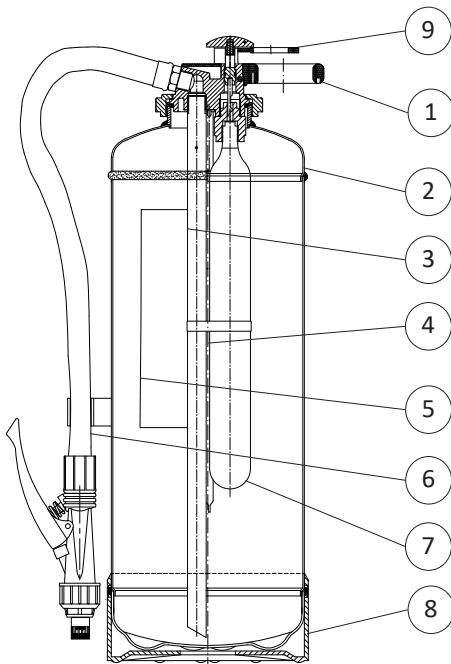

SPARE PARTS

NUMBER	DESCRIPTION	CODE
1	Valve M. 74x2	3008-1
2	Cylinder	3011-1
3	PVC dip tube	3033
4	Pressurization dip tube	3033-1
5	Label	3015-2
6	Hose	3014
7	gr. 150 CO ₂ cartridge	3030
8	PELD base	1862-6
9	Safety pin	0285-1
	Safety pin seal	0285
	BC powder - Potassium Sulphate (25 Kg recharge)	2051

File name	Code	Date	Rele.	Check	Rev.	Pag.
ds_25064-1	25064-1	30/10/17	M.R		1	2

EMME ANTINCENDIO S.r.l

Via del Molino, 40 - 52010 Corsalone (AR) - Italy
info@emme-italia.com - Tel. +39.0575.511320

Others Emme Antincendio s.r.l. warehouses in Italy : Milano - Padova - Reggio Emilia
P.IVA/ C.F. 11208251006 - R.E.A. FI-632545